

■ Features :

- 180-264VAC input only
- Fully encapsulated with IP67 level (Note.5)
- Protections:Short circuit / Over load / Over voltage / Over temperature
- Cooling by free air convection
- Class II power unit, no FG
- Pass LPS
- 100% full load burn-in test
- Suitable for LED lighting and moving sign applications
- High reliability / Low cost
- 2 years warranty



**SPECIFICATION**

MODEL	LPH-18-12	LPH-18-24	LPH-18-36	
OUTPUT	DC VOLTAGE	12V	24V	36V
	RATED CURRENT	1.5A	0.75A	0.5A
	CURRENT RANGE	0 ~ 1.5A	0 ~ 0.75A	0 ~ 0.5A
	RATED POWER	18W	18W	18W
	RIPPLE & NOISE (max.) Note.2	120mVp-p	150mVp-p	200mVp-p
	VOLTAGE TOLERANCE Note.3	±3.0%		
	LINE REGULATION	±1.0%		
	LOAD REGULATION	±2.0%		
INPUT	SETUP, RISE TIME	1500ms, 30ms / 230VAC		
	HOLD UP TIME (Typ.)	50ms/230VAC at full load		
	VOLTAGE RANGE	180 ~ 264VAC	254 ~ 370VDC	
	FREQUENCY RANGE	47 ~ 63Hz		
	EFFICIENCY(Typ.)	78%	82%	83%
	AC CURRENT	0.3A/230VAC		
	INRUSH CURRENT(max.)	Cold start 50A/230VAC		
PROTECTION	LEAKAGE CURRENT	0.25mA / 240VAC		
	OVER LOAD	Above 105% rated output power Protection type : Hiccup mode, recovers automatically after fault condition is removed		
	OVER VOLTAGE	13.8~ 16.2V	27.6~ 32.4V	41.4 ~ 48.6V
ENVIRONMENT	OVER TEMPERATURE	Tj 170 typically (U1) Detect on main control IC Protection type : Hiccup mode, recovers automatically after temperature goes down		
	WORKING TEMP.	-30~ +70°C (Refer to "Derating Curve")		
	WORKING HUMIDITY	20 ~ 90% RH non-condensing		
	STORAGE TEMP., HUMIDITY	-40 ~ +80°C, 10 ~ 95% RH		
	TEMP. COEFFICIENT	±0.03%/°C (0 ~ 50°C)		
SAFETY & EMC (Note 4)	VIBRATION	10 ~ 500Hz, 2G 10min./1cycle, period for 60min. each along X, Y, Z axes		
	SAFETY STANDARDS	TUV EN60950-1, IP67 approved; design refer to UL1310 Class 2,EN61347-2-13, CAN/CSA C22.2 No. 223-M91		
	WITHSTAND VOLTAGE	I/P-O/P:3KVAC		
	ISOLATION RESISTANCE	I/P-O/P:>100M Ohms / 500VDC / 25°C / 70% RH		
OTHERS	EMC EMISSION	Compliance to EN55022 (CISPR22) Class B, EN61000-3-2 Class A, EN61000-3-3		
	EMC IMMUNITY	Compliance to EN61000-4-2,3,4,5,6,8,11, EN55024, light industry level, criteria A		
	MTBF	1200.6K hrs min. MIL-HDBK-217F (25 )		
NOTE	DIMENSION	140*30*22(L*W*H)		
	PACKING	0.175Kg; 70pcs/13.3Kgs/0.71CUFT		
<p>1. All parameters NOT specially mentioned are measured at 230VAC input, rated load and 25°C of ambient temperature.                  2. Ripple &amp; noise are measured at 20MHz of bandwidth by using a 12" twisted pair-wire terminated with a 0.1uF &amp; 47uF parallel capacitor.                  3. Tolerance : includes set up tolerance, line regulation and load regulation.                  4. The power supply is considered as a component that will be operated in combination with final equipment. Since EMC performance will be affected by the complete installation, the final equipment manufacturers must re-qualify EMC Directive on the complete installation again.                  5. Suitable for indoor use or outdoor use without direct sunlight exposure.</p>				

File Name: LPH-18-SPEC 2011-11-08

**Mechanical Specification**

Unit:mm

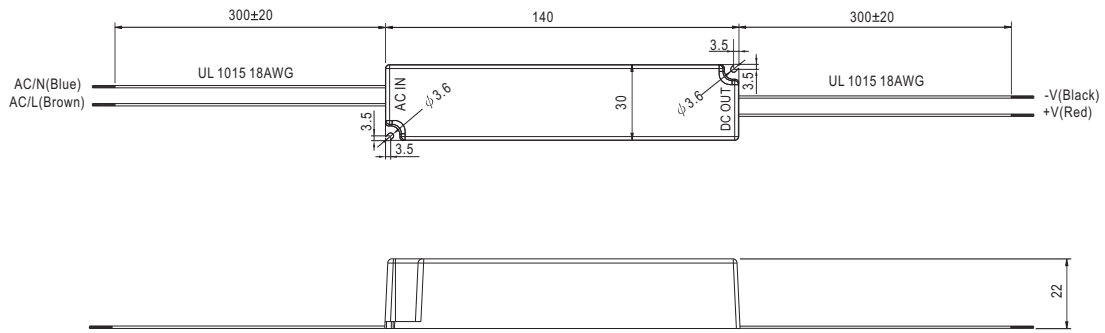

**Block Diagram**

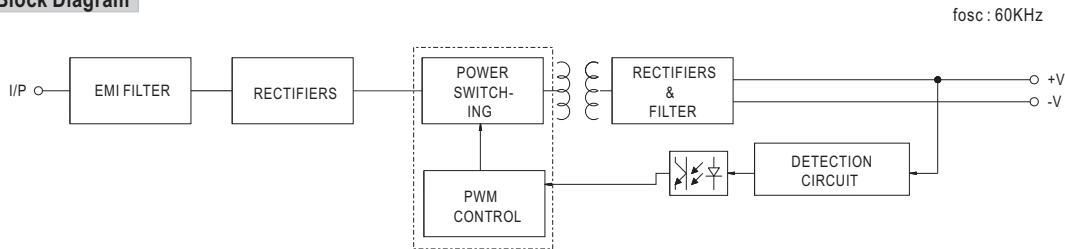

**Derating Curve**

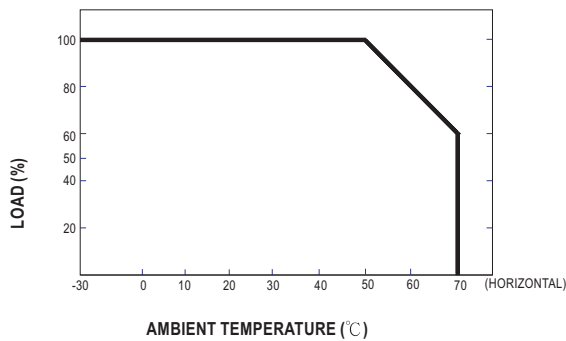

**Static Characteristics**

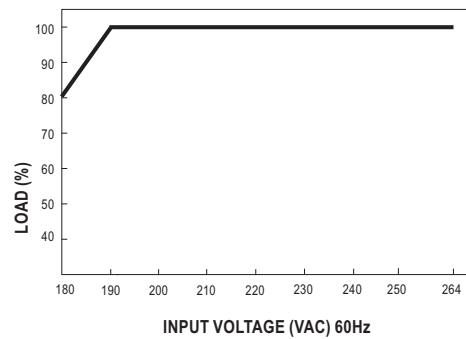

File Name: LPH-18-SPEC 2011-11-08